



Safety for Industrial Process

Industrial Range

F series

Pressure switches and
Temperature switches



Characteristics*

- Gauge, absolute or differential pressure control
- Temperature control: direct bulb or through capillary
- Electrical contact or pneumatic signal output
- Protection for areas involving an explosion risk (ATEX)
 - Explosion-proof enclosure
 - Intrinsic safety
 - Increased safety
 - Explosion-proof contact
 - Constructional safety

OTHER SPECIFIC FEATURES

- Compact industrial series
- Low vibration sensitivity
- SIL2 capability
- Harsh environment versions available on request
- Made in France

* According to model



www.georgin.com



Contents

Introduction	3
Applications	
Working principle	
Construction	4
Type of housing	
Type of sensing element and connection	
Operating temperature limits	
Ambient operating temperature limits	
Storage temperature	
Reproducibility	
Recommendations	
Equipment designed for EXplosive ATmospheres (ATEX)	5
Intrinsic safety	
Increased safety	
Explosion-proof safety	
Electrical or pneumatic functions	6
Electrical contact	
Electrical function	
Pneumatic function	
Code numbers	8
Gauge pressure switches: ranges and dead bands	10
Diaphragm-actuated gauge pressure switches	
Bellows-actuated gauge pressure switches	
Bourdon tube pressure switches	
Absolute and differential pressure switches: ranges and dead bands	11
Bellows-actuated absolute pressure switches	
Diaphragm-actuated differential pressure switches	
Bellows-actuated differential pressure switches	
Temperature switches: ranges and dead bands	12
Direct bulb temperature switches (vapour pressure)	
Bulb and capillary temperature switches (vapour pressure)	
Bulb design and capillary length	
Specific features associated with mounting temperature switches	13
Immersion pockets (mechanically welded) with capillary cable gland	
Capillary protection	
Capillary cable gland	
Dimensional drawings	14
Housing assemblies	
Sensor assemblies	
Certifications and qualifications	16

Note:

Subject to modifications due to technical advances

Introduction

GEORGIN F Series PRESSURE SWITCHES and TEMPERATURE SWITCHES offer an extensive range of equipment suitable for the harshest operating conditions. The series is a justified choice whenever precision and reliability are necessary criteria.

APPLICATIONS

- thermal or nuclear energy generation
- the oil industry, from drilling to refining
- chemical and petrochemicals
- natural or liquefied gas transport and storage
- gas supercharging
- gas, steam or hydraulic turbines
- diesel engines, pumps and compressors
- shipbuilding for merchant or military navy
- steam circuits, furnaces and burners
- rail transport braking safety
- silos
- water treatment

SMOOTH ARTICULATION PRESSURE AND TEMPERATURE SWITCHES FOR INDUSTRIAL USE WHERE HIGH RESISTANCE TO VIBRATIONS IS REQUIRED

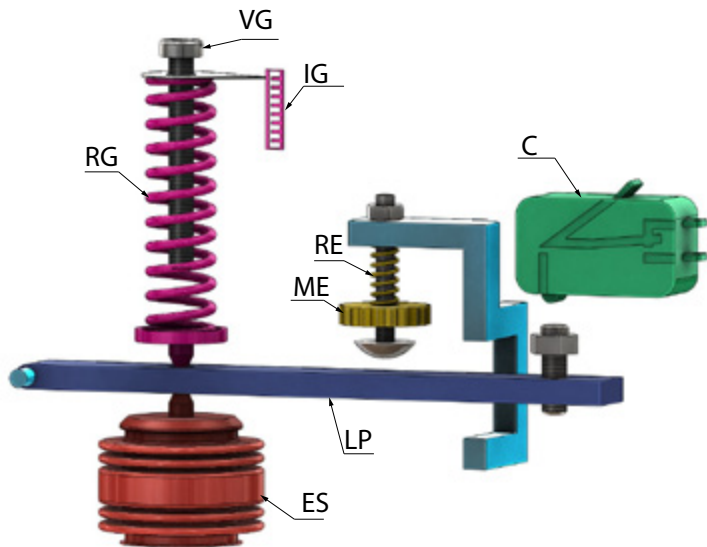

VG	Set point (Range adjustment screw)
RG	Range spring
IG	Range index
RE	Dead band adjustment spring
ME	Dead band adjustment knob
ES	Sensing element
C	Switch
LP	Flexible arm

WORKING PRINCIPLE

The pressure or temperature is applied to the sensing element (SE), whose position then changes, acting on the flexible arm (FA). The force produced in this way is balanced by the spring (RS). This is how the set point is adjusted. As the set point is approached, the change in forces disturbs the balance (FA) and acts on the contact.

A second spring (DBS) acting on the flexible arm (FA) increases the deviation of the switch(es). The force produced by the dead band spring is adjustable, and is used to offset the two contacts in the case of differential functions.

NOTE: The pressure switch and temperature switch scales indicated in our catalogue are values for a set point to lower the pressure or temperature.

TYPES OF HOUSINGS

- Standard housing: zamak, aluminium cover, epoxy paint coating
- Explosion-proof housing (RTPF): AS10G aluminium, epoxy paint coating
- Polyester housing (FPP)
- 316L/1.4404 stainless steel housing (FPX)

316 stainless steel external screws and fittings

IP 66 (IP68 available as an option)

IP 56 (IP66 available as an option) for diaphragm-actuated gauge pressure switch in FML, FMS, FMT type standard housing as per EN 60 529 (IEC 529)

External ground terminal

Plumbing is performed directly using wires for FPP and FPX type instruments and requires a specific external kit for the standard and explosion-proof models.

A stainless steel identification plate is fitted on an all polyester or stainless steel explosion-proof type instruments, and on increased safety instruments.

Options:

Stainless steel identification plate for standard instruments and Intrinsically safe models

Special setting range

Factory setting and plumbing

Inner graduated scale with viewing window

Respirator to limit condensation phenomena (IP 56) in standard housing

Wall mounting using M5 threads, lugs, mounting bracket or 2" mounting kit

TYPE OF SENSING ELEMENT AND PROCESS CONNECTION

Bellows-actuated technology offers a high repeatability. It is recommended for stable processes, not subject to pulses or pressure surges. Bellows are available in bronze or 316L/1.4404 stainless steel versions.

Diaphragm-actuated technology is suitable for meeting 2 constraints:

- processes with pulsating phenomena or subject to pressure surges
- low or very low pressure control

The material used for the diaphragms will be NBR (such as Perbunan®) as standard, or FKM (such as Viton®) or Ethylene-Propylene. The flanges will be made of 304L/1.4307 stainless steel for (D)FML and 316L stainless steel for FPA, (D)FMS, (D)FMT.

The 316L stainless steel Bourdon tube will be used for very high pressure control up to 1000 bar.

Types of connections:

- G½" as per EN ISO 228-1 as standard
- G¼" M as per EN ISO 228-1 for diaphragm-actuated pressure switches except for (D)ML model
- NPT connector as per ANSI/ASME B1.20.1

Other connector types available on request.

Depending on the type and range, the instruments may be equipped with separators with or without capillary.

OPERATING TEMPERATURE LIMITS (PRESSURE SENSING ELEMENT)

Bronze bellows:	-20	to	+60°C	NBR diaphragm:	-20	to	+100°C
Stainless steel bellows:	-40	to	+150°C	EP diaphragm:	-40	to	+120°C
Stainless steel tube	-40	to	+150°C	FKM diaphragm:	+0	to	+150°C

AMBIENT OPERATING TEMPERATURE LIMITS (HOUSING) STORAGE TEMPERATURE

-20 to +70°C - others on request.

For temperature switches from the C and G ranges: max. 55°C. B range: max. 50°C.

REPRODUCIBILITY

Less than or equal to ±1% of the measurement range for constant cycle and temperature.

Greater than ±1% of the measurement range in constant cycle and temperature for FPH and FDH type sensors, for diaphragm-actuated instruments having a range of ≤40mbar and for FX range bellows-actuated sensors.

RECOMMENDATIONS

For all F series equipment, refer to the operating and maintenance manual FU-F-EN.

For ATEX equipment, refer to the ATEX instruction manual: FI-F-EN.

These documents and the accessory data sheets are available for download from our website www.georgin.com.



Equipment designed for EXplosive ATmospheres (ATEX)

The tables below enable you to ascertain the product certification according to the protection index (IP66 except for FML, FMS, FMT which are IP56 unless specially requested otherwise) and the required installation area.

INTRINSIC SAFETY

Principle: gold-plated contact for low current to be associated with an I.S. interface (see fc-rdn-fren)



Housing: standard

Protective enclosure	IP66 - IP68	IP56
Marking	CE 0081  II 1GD Exia IIC T6 - Ex iaD 20	CE 0081  II 1G/3D Exia IIC T6 - Ex iaD 22
Installation areas	0 / 1 / 2 for gas groups IIA, IIB, IIC 20 / 21 / 22 for dust	0 / 1 / 2 for gas groups IIA, IIB, IIC 22 for non-conductive dust
Instrument category	1GD	1G/3D (non-conductive dust)
Maximum surface temperature: 80°C	—	-40°C < Operating ambient temperature < 80°C
CE type examination statement Type examination statement	LCIE 01 ATEX 6008X	LCIE 01 ATEX 6008X LCIE 08 ATEX 6057X (voluntary statement)

INCREASED SAFETY

Principle: explosion-proof contact "d" - terminal block + increased safety cable gland "e"

Housing: standard or polyester "e" FPP type (off-shore application)

Protective enclosure	IP66 - IP68	IP56
Marking	CE 0081  II 2GD Exde IIC T6 - Ex tD A 21	CE 0081  II 2G/3D Exde IIC T6 - Ex tD A 22
Installation areas	1 / 2 for gas groups IIA, IIB, IIC 21 / 22 for dust	1 / 2 for gas groups IIA, IIB, IIC 22 for non-conductive dust
Instrument category	2GD	2G/3D (non-conductive dust)
Maximum surface temperature: 80°C	—	-20°C < Operating ambient temperature < 60°C
CE type examination statement Type examination statement	LCIE 02 ATEX 6161X	LCIE 02 ATEX 6161X LCIE 08 ATEX 6057X (voluntary statement)

EXPLOSION-PROOF SAFETY

Principle: explosion-proof unit "d"



Housing: RTPF type

Protective enclosure	IP66 - IP68	
Marking	CE 0081  II 2GD Exd IIC T6 - Ex tD A21 (with or without line resistors)	
Installation areas	1 / 2 for gas groups IIA, IIB, IIC 21 / 22 for dust	
Instrument category	2GD	
Maximum surface temperature: 80°C	—	-40°C < Operating ambient temperature < 80°C
CE type examination statement	LCIE 01 ATEX 6071X	

Caution: the use of the cable gland must comply with the standard EN 60.079-14 § 10.4 (RTPF inner volume < 2dm3)

Principle: explosion-proof contact "d" with moulded cable output

Housing: standard or polyester "e" FPP type (off-shore application)

Protective enclosure	IP66 - IP68	IP56
Marking	CE 0081  II 2GD Exd IIC T6 - Ex tD A 21	CE 0081  II 2G/3D Exd IIC T6 - Ex tD A 22
Installation areas	1 / 2 for gas groups IIA, IIB, IIC 21 / 22 for dust	1 / 2 for gas groups IIA, IIB, IIC 22 for non-conductive dust
Instrument category	2GD	2G/3D (non-conductive dust)
Maximum surface temperature: 80°C	—	-40°C < Operating ambient temperature < 80°C
CE type examination statement Type examination statement	LCIE 01 ATEX 6071X	LCIE 01 ATEX 6071X LCIE 08 ATEX 6057X (voluntary statement)

CONSTRUCTIONAL SAFETY (PNEUMATIC MODELS)

Principle: constructional safety

Housing: Standard or Polyester

Protective enclosure	IP66	IP56
Marking	II 2GD c IIC Tx (-20°C < Ta < 60°C) IP66 T...°C	II 2G 3D c IIC Tx (-20°C < Ta < 60°C) IP56 T...°C
Installation areas	1 / 2 for gas groups IIA, IIB, IIC 21 / 22 for dust	1 / 2 for gas groups IIA, IIB, IIC 22 for non-conductive dust
Instrument category	2GD	2G 3D
Technical file c	0610 - LCIE 10 AR 046 NM	

Electrical or pneumatic functions

ELECTRICAL CONTACT

The electrical contacts used by GeorGIN are SPDT type. At rest, contact is established between C-NC.

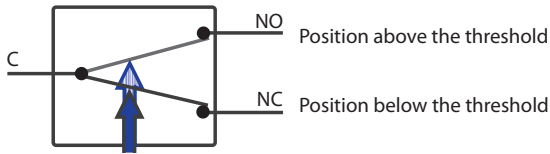

According to the type of action (opening or closure of the electrical circuit), the electrical connection is made on the terminal block between C-NC or C-NO.

ELECTRICAL FUNCTIONS

		Fixed dead band ⁽¹⁾	Adjustable dead band ⁽²⁾
1 Change-over ⁽¹⁾⁽²⁾ (SPDT)	Standard	4, 4 D	6, 6 D
	Tight dead band	10, 10 D, 16, 16 D	-
	Nitrogen sealed	-	96
	Explosion-proof	-	62, 62 C, 62 D
	Expl. pr. (tight dead band)	60, 60 C, 60 D	-
2 SPDT ⁽³⁾ (acting together)	Standard	-	34, 34 D
	Nitrogen sealed	-	106
	Explosion-proof (Expl. pr.)	-	162 C
	Expl. pr. (tight dead band)	160 C	-
		Adjustable lagging	
2 SPDT ⁽⁴⁾ (two steps)	Standard	54, 54 D	
	Nitrogen sealed	116	
	Explosion-proof (Expl. pr.)	172 C	
	Expl. pr. (tight dead band)	170 C	

(1). Single fixed dead band electrical operation:

Microswitch "only". Each type of microswitch has its own characteristics, as indicated in the catalogue. Models: 4, 4D, 10, 10D, 16, 16D, 60, 60C, etc.

(2). Single adjustable dead band electrical operation:

Microswitch combined with a dead band spring (DBS) to increase the microswitch dead band value in a given range (refer to the dead band table in the catalogue, page 10, 11, 12).

The trigger value of the upper threshold can be offset using the dead band spring DBS.

This action has no effect on the lower threshold. Models: 6, 6D, 12V, 96, 62, 62C, etc.

(3). Electrical operation with two simultaneous contacts:

Combination of two single functions set to act at the same time, either upwards or downwards. The dead band of a simultaneous function is greater than that of a single function. The synchronisation dead band at re-engagement should not be more than 1% of the mean dead band.

Fixed dead band model: 160C, etc. Adjustable dead band models: 34, 34D, 106, 162C, etc.

(4). Electrical function with two offset contacts:

Combination of two single functions adjusted to act with a gap between. The dead band spring (DBS) is used to adjust the gap between the interlocking of the switches.

Models: 54, 54D, 116, 172C, 172, 170C, 170, etc.

Remarks:

The electrical functions 60C, 62C, 160C, 162C, 170C and 172C consist of explosion-proof contacts (Ex) equipped with 1m of pre-assembled cable (3 or 5 m available as an option) which must be connected to an approved terminal block.

The electrical functions 4D/6D/34D/54D, 10D, 16D, 60D, 62D consist of gold-plated contacts, suitable for use at low levels for PLCs, and also for intrinsic safety instruments.

The contacts 4, 6, 34, 54 are tropicalised as standard.

Electrical or pneumatic functions

Maximum breaking capacity (resistive load)

Contact No.	AC		DC	
	Current (A)	Voltage (V)	Current (A)	Voltage (V)
4/6/34/54	10A	240V	0.5A	110V
10	5A	240V	0.5A	130V
16	2A	240V	1A	130V
96/106/116	2.5A	240V	1A	130V
4D/6D/34D/54D	-	-	1mA/100mA	4V/30V
10D	-	-	50mA	30V
16D/60D/62D	-	-	10mA / 100mA	6V / 24V
62/62C/162C/172C	5A	240V	0.4A	250V
60/60C/160C/170C	7A	240V	0.25A	250V
12V	10A	240V	-	-

Cable inlets

The instruments (with the exception of polyester, stainless steel housings & explosion-proof housing) have one M16 type cable inlet and are supplied with 1 or 2 cable glands 5 to 10 mm in diameter (standard and I.S. instrument). The instrument can also be supplied without cable inlets.

Explosion-proof housings are supplied as standard with a 3/4" NPT type cable inlet.

Cable glands are available as an option. The choice of cable gland directly affects the certification, and could lead to the equipment being declassified. Refer to the ATEX instruction sheet.

Polyester housings (FPP) are equipped as standard with an ISO M20-certified Ex ed cable gland 6 to 13 mm in diameter (Ex de instrument).

Stainless steel housings (FPX) are equipped as standard with an ISO M20-certified stainless steel cable gland 6 to 13 mm in diameter.

Other cable gland models are available on request.

Internal terminal blocks

The terminal blocks are designed for the following maximum wire size: 2.5 mm² for standard models and 1.5 mm² for ATEX models.

PNEUMATIC FUNCTION

The instruments can be equipped with one or more Normally Open (NO) or Normally Closed (NC) pneumatic functions using a spool or poppet valve.

Georgin offers single, simultaneous double, and offset double pneumatic functions.

The supply fittings are M5, 1/4, or 1/8 gas threaded according to the type of function and/or the model.

According to the type of cell, the control pressure will be:

- As standard: 1.5 to 8 bar (spool design <> with a residual leak).
- On request for NC cell: 0 to 10 bar (poppet design <> without leak).

The control fluid must be compatible with the ISO-VG 10 standard (air, nitrogen, etc.).

Maximum allowable filtration 5 µm.

The standard materials for the cell body are polyamide, brass, and/or aluminium. The seals are made of NBR (other types on request).

For certain models, exhaust is via open cable gland or screw terminal (mandatory for ATEX models).

The control pressure applied to the unit affects the dead band: the lower the supply pressure, the smaller the dead band, and vice-versa.

At rest, the pneumatic function is set as follows:

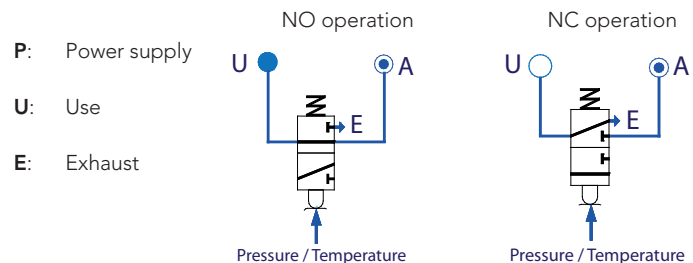

Pneumatic function type	Reference
normally open	NO
normally closed	NC
change over	IP
double NO and NC with adjustable lagging	OC
double NC and NO with adjustable lagging	CO
double NO+NO with adjustable lagging	DO
double NC+NC with adjustable lagging	DC
double simultaneous fixed dead band NO+NO	SO
Double simultaneous fixed dead band NC+NC function	SC
Double simultaneous fixed dead band NO+NC function	SN

Instrument type pages 4, 10, 11, 12	
FV	Bellows-actuated absolute pressure switch
FML FMS FMT FPA (S)	Diaphragm-actuated gauge pressure switch
FP FPH	Bellows-actuated gauge pressure switch
FPL	Bourdon tube gauge pressure switch
DFML DFMS DFMT	Diaphragm-actuated differential pressure switch
FD FDH	Bellows-actuated differential pressure switch
FB FBA	Direct bulb temperature switch
FC	Bulb and capillary temperature switch

Specific features	
	Standard housing
P	Polyester housing. Can only be associated with the electrical functions 60(C), 62(C), 160(C), 162(C), 170(C), 172(C)
X	Stainless steel housing

Function type pages 6 and 7	
4 / 4D 10 / 10D 16 / 16D 60 / 60C	Single electrical function with fixed dead band
6 / 6D 96 62 / 62C	Single electrical function with adjustable dead band
160C	Electrical function with 2 simultaneous contacts with fixed dead band*
34 / 34D 106 162C	Electrical function with 2 simultaneous contacts with adjustable dead band*
54 / 54D 54V 116 172C 170C	Electrical function with 2 offset contacts
NO / NC IP OC / CO DO / DC SO / SC SN	Pneumatic function

* refer §(3) page 6

Georgin has one of the most extensive ranges of electromechanical and electropneumatic security solutions in the world.

Because our product range is subject to ongoing development and so as not to impact the safety of your installations, this document enables you to define your overall reference. We will confirm this with our item code.

Examples of code numbers

FPAS		4	P	
-------------	--	----------	----------	--

Diaphragm-actuated gauge pressure switch (material to be defined) and galvanised steel flange
Standard housing
With fixed dead band electrical operation
Range: 0.5..10bar // Pmax: 200bar

FC	P	160C	R2X	
-----------	----------	-------------	------------	--

Stainless steel bulb and capillary temperature switch
Polyester housing and electrical output via cable
With fixed dead band electrical operation with two simultaneous contacts
Range: 65..170°C

DFML		54	BX	RTPF
-------------	--	-----------	-----------	-------------

Diaphragm-actuated differential pressure switch (material to be defined) and stainless steel flange
Explosion-proof housing
With electrical operation with two offset contacts
Range: 0..20mbar

FP	X	6	RX	
-----------	----------	----------	-----------	--

Stainless steel bellows-actuated pressure switch
Stainless steel housing
With single adjustable dead band electrical operation
Range: 5..50bar
Pmax: 200bar

PX

RTPF

Range and qualification of metal parts in contact with fluid

The range information is detailed in the next 3 pages.

The information "X" denotes, according to the type of instrument, that the connector, bellows, Bourdon tube and the flange of the diaphragm-actuated instrument or the the thermostatic element are made of stainless steel.

In addition to the reference, we request you to specify for a pressure switch:
 - The type of connector (1/2"GM, 1/4"NPTF, mounting on separator, etc.)
 - The diaphragm material if applicable (NBR, FKM or E.P.)
 If a treatment such as degreasing, passivation or a helium test is to be envisaged, please specify this.

For a temperature switch:
 - The type of bulb
 - Its dimensions
 and if applicable, the type of capillary, its length and protection.

Specific features

Standard housing

Explosion-proof housing

RTPF

Cannot be associated with the electrical functions 60(C), 62(C), 160C, 162C, 170C, 172C

DEAD BAND TABLE READING GUIDE

Applicable to tables on pages 10/11/12
 Example on FP . P(X) type pressure switch

FP . P(X) denotes an F series gauge pressure switch.

The sensing element of the FP . P is made of bronze and offers a continuous Pmaximum of 13 bar. For a FP . PX stainless steel bellows-actuated switch, the maximum pressure is 15 bar. Its setting range is 0.5 to 10 bar for a **pressure lowering set point**. Please note that the setting range for a pressure increasing set point is dependent on the associated microswitch.

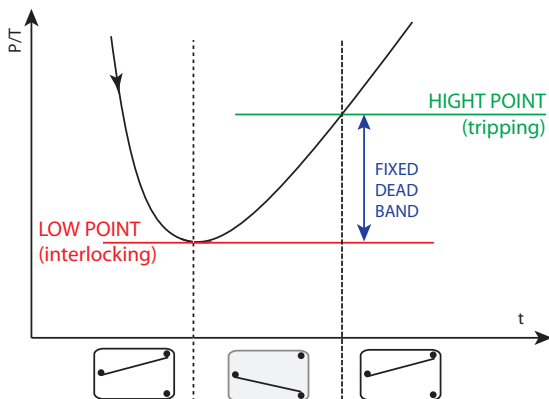

Example of set point to lower P/T

Type	Range	1 SPDT									Max. dead band ≤	P max
		fixed dead band ≤				adjustable dead band ≤						
		4	10	16	60	6	62	96	34	106		
	bar	mbar									bar	
FP . P (X)	0.5 to 10	285	55	30	140	285	450	400	335	650	2	13 (15)



■ Fixed dead band electrical operation

	4 / 4D	10 / 10D	16 / 16D	60 / 60C
fixed dead band	285 mbar	55 mbar	30 mbar	140 mbar

■ Adjustable dead band electrical operation

	6 / 6D	62 / 62C	96
min dead band	285 mbar	450 mbar	400 mbar
max dead band	2 bar		

■ Electrical operation with two simultaneous contacts

	34 / 34D	160C	162C	106
min dead band	335 mbar	~ dead band of function 60 x1.5	~ min dead band of function 62 x1.5	~ 650 mbar
max dead band	2 bar	N.A. (fixed dead band)	2bar	

■ Electrical operation with two offset contacts

	54 / 54D	170C	172C	116
1 st microswitch	~ 285 mbar - min dead band of function 4	~min dead band of function 60	~ min dead band of function 62	~ 650 mbar

Regardless of the double offset electrical function, the dead band between the first increasing set point and the second lowering set point must be within the setting range equivalent to the rangeability offered by function 6, i.e. between 285mbar and 2bar. Otherwise, please consult us.

	2 nd microswitch	~ dead band of function 4 x1.5	~ dead band of function 60 x1.5	~ min dead band of function 62 x1.5	~ dead band of function 96 x1.5

Gauge pressure switches: ranges and dead bands

DIAPHRAGM-ACTUATED GAUGE PRESSURE SWITCHES

Type	Range	1 SPDT												2 SPDT				Max. dead band \geq	P max		
		fixed dead band \leq						adjustable dead band \leq													
	4	10	16	60	6	62	96	34	106	mbar								mbar	bar		
	mbar	L	H	L	H	L	H	L	H	L	H	L	H	L	H	L	H	L	H		
FML . B (X)	0 to 20	2.7	3.5	0.8	1.1	0.4	0.5	1.6	2.2	2.7	3.5	5	7	3.0	4.0	3.2	4.2	-	-	20	+/-0.3
FML . C (X)	0 to 40	3	4	0.9	1.2	0.5	0.6	1.8	2.4	3	4	5.5	7.5	3.5	4.5	3.7	4.7	-	-	20	+/-0.3
FML . D (X)	-50 to 10	4	5	1.1	1.4	0.6	0.9	2.2	2.8	4	5	7	9	4.5	5.5	4.8	6.2	-	-	20	+/-0.3
FML . H (X)	0 to 80	3.5	4.5	1.3	1.3	0.5	0.7	2.6	2.6	3.5	4.5	6.5	8	4.0	5	4.2	5.5	-	-	20	+/-0.3
FMS . JX	0 to 500	52	63	10	12	4	5	20	24	52	63	75	95	50	70	60	70	80	95	200	80
FMS . MX	0 to 1000	60	70	11	15	5	6	22	28	60	70	80	105	55	75	65	80	85	105	200	80
FMT . F (X)	10 to 250	25	32	5	6	2	2.5	10	12	25	32	37	50	25	35	30	35	40	50	100	200
FMT . G (X)	10 to 500	28	35	5.5	7.5	2.5	3	11	14	28	35	45	55	30	40	35	40	45	55	100	200
	bar	Pulses or transient pressure surge																		bar	
FPA . K (X)	-1 to 5	160	240	30	45	16	24	70	105	160	240	200	300	170	260	200	300	270	400	1	● 80
FPA . P (X)	▲ 0.5 to 10	275	480	50	75	30	45	120	185	275	480	350	560	400	500	320	520	500	750	2	● 80
FPA . Q (X)	2.5 to 25	700	980	120	175	60	90	300	400	700	980	810	1200	750	1050	750	1100	1100	1600	5	● 80
FPA . R (X)	5 to 50	2100	5800	500	1400	200	400	750	2200	2100	5800	2500	7500	2200	4000	2300	5800	3500	5500	10	● 80

● 200 bar version available - Code changes to FPAS

▲ For P (X) range pressure switches equipped with change-overs 96 or 106, the range becomes: 1 to 10 bar
The "L" and "H" columns give the min dead bands for set points in the Lowest or Highest part of the range.

BELLOWS-ACTUATED GAUGE PRESSURE SWITCHES

Type	Range	1 SPDT												2 SPDT				Max. dead band \geq	P max		
		fixed dead band \leq						adjustable dead band \leq													
	4	10	16	60	6	62	96	34	106	mbar								bar			
	bar	mbar																		bar	
FP . AX	-1 to 0	35	7.5	4	17	35	54	45	40	70	0.25	2									
FP . FX	■ 0 to 0.25	18	4	3.2	14	18	34	35	24	60	0.25	2									
FP . GX	■ 0 to 0.5	21	5	3.3	15	21	37	37	27	62	0.25	2									
FP . MX	■ 0 to 1	26	5.5	3.5	15	26	45	40	32	65	0.25	2									
FP . LX	-1 to 1	75	15.5	7	35	75	115	85	85	130	0.5	■ 8									
FP . NX	◆ 0.1 to 2	55	11.5	6	30	55	85	70	65	125	0.5	■ 8									
FP . K (X)	-1 to 5	205	40	20	90	205	310	250	225	380	1	13 (15)									
FP . P (X)	▲ 0.5 to 10	285	55	30	140	285	450	400	335	650	2	13 (15)									
FP . QX	2.5 to 25	700	140	70	305	700	1100	800	800	1300	5	30									
FP . RX	5 to 50	1600	320	150	700	1600	2400	1800	1750	2800	10	80									
FP . SX	10 to 125	5200	1000	400	2000	5200	7700	5000	5600	7500	20	250									
FPH . GX	● 0 to 0.5	40	9	● 6	26	40	70	70	50	55	0.5	■ 8									
FPH . KX	-0.5 to 6	550	140	40	190	550	750	500	600	500	1.5	30									
FPH . PX	1 to 10	600	150	40	200	600	800	550	650	700	1.5	30									

● for autoclaves

▲ For pressure switches equipped with SPDT 96, 106 or 116, the bottom of the range is: 1 bar

■ For pressure switches equipped with SPDT 96, 106 or 116, the bottom of the range is: 0.05 bar

◆ For pressure switches equipped with SPDT 96, 106 or 116, the bottom of the range is: 0.2 bar

● For pressure switches equipped with SPDT 96, 106 or 116, the bottom of the range is: 0.05 bar

■ For RPTF type pressure switches, the maximum pressure will be limited to 7 bar

BOURDON TUBE PRESSURE SWITCHES

Type	Range	1 SPDT												2 SPDT				Max. dead band \geq	P max		
		fixed dead band \leq						adjustable dead band \leq													
	4	10	16	60	6	62	96	34	106	bar								bar			
	bar	bar																		bar	
FPL . TX	10 to 200	18	4	1.6	7.5	18	28	19	20	30	100	300									
FPL . VX	25 to 400	36	8	3.2	15.5	36	57	40	45	60	200	600									
FPL . YX	50 to 800	72	16	6.4	31	72	114	80	90	120	250	1000									

Absolute and differential pressure switches: ranges and dead bands

BELLEWS-ACTUATED ABSOLUTE PRESSURE SWITCHES

Type	Range (absolute)	1 SPDT								2 SPDT		Max. dead band \geq	P max
		fixed dead band \leq				adjustable dead band \leq							
		4	10	16	60	6	62	96	34	106	bar		
	bar	mbar								bar			
FV .HX	0.05 to 1	45	12	5	22	45	65	55	50	85	0.25	3	
FV .NX	0.1 to 2	100	30	10	115	100	160	120	110	170	0.5	◆ 9	
FV .M (X)	0.2 to 6	300	60	25	255	300	450	300	320	410	1	14	

◆ For RPTF type pressure switches, the maximum pressure will be limited to 8 bar absolute

DIAPHRAGM-ACTUATED DIFFERENTIAL PRESSURE SWITCHES

Type	Range ΔP	1 SPDT										2 SPDT				Max. dead band \geq	Stat. P min/max (operating)				
		fixed dead band \leq					adjustable dead band \leq														
		4	10	16	60	6	62	96	34	106	mbar				mbar			bar			
	mbar	L	H	L	H	L	H	L	H	L	H	L	H	L	H	L	H	L	H		
DFML .B (X)	0 to 20	3.0	4.0	0.9	1.2	0.5	0.6	1.8	2.4	3.0	4.0	5.5	7.5	3.5	4.5	3.6	4.7	-	-	20	-0.3/0.3
DFML .C (X)	0 to 40	3.5	4.4	1	1.3	0.6	0.7	2	2.6	3.5	4.4	6	8.5	4	5	4.2	5.3	-	-	20	-0.3/0.3
DFML .H (X)	0 to 80	4.0	5.2	1.1	1.4	0.6	0.8	2.2	2.8	4.0	5.2	7	9	4.5	5.5	4.8	6.2	-	-	20	-0.3/0.3
DFMS .JX	50 to 500	75	90	15	18	5.5	6.5	28	32	75	90	110	135	70	85	80	100	95	115	200	P.atm/80
DFMS .MX	50 to 1000	80	100	18	22	6	7.5	30	36	80	100	115	155	75	95	85	110	100	130	200	P.atm/80
DFMT .F (X)	10 to 250	35	45	7.5	9	3	3.5	14	16	35	45	55	70	35	45	40	50	50	60	100	P.atm/200
DFMT .G (X)	10 to 500	40	50	9	11	3	4	15	18	40	50	60	80	40	50	45	55	55	65	100	P.atm/200

BELLEWS-ACTUATED DIFFERENTIAL PRESSURE SWITCHES

Type	Range ΔP	1 SPDT										2 SPDT				Max. dead band \geq	Stat. P min/max (operating)
		fixed dead band \leq					adjustable dead band \leq										
		4	10	16	60	6	62	96	34	106	mbar				bar		
	bar	mbar										bar					
FD .HX	0.05 to 1	45	12	5	25	45	70	60	50	85	0.25	-1/2					
FD .NX	0.1 to 2	100	30	10	45	100	160	120	110	170	0.5	-1/8 ■					
FD .MX	0.2 to 5	300	65	25	120	300	450	330	320	450	1	-1/15					
FD .P (X)	0.5 to 10	410	85	35	165	410	625	430	450	700	2	0.5/13 (15)					
FD .QX	1 to 20	1100	240	85	420	1100	1650	1150	1200	1600	5	2.5/30					
FD .RX	2.5 to 50	2500	550	190	950	2500	3700	2600	2600	3500	10	5/80					
FD .SX	5 to 100	8600	1800	550	2700	8600	12600	7000	9000	10000	20	10/250					
FDH .GX	0.05 to 0.5	90	24	9	44	90	140	110	100	150	0.5	0/8 ■					
FDH .NX	0.4 to 2	900	180	50	280	900	1350	750	950	950	1.5	2.5/30					
FDH .PX	0.5 to 10	1000	200	80	400	1000	1500	950	1100	1500	5	2.5/30					
FDH .QX	1 to 20	2300	510	186	940	2300	3400	2400	2450	3400	10	5/80					

■ For RPTF type pressure switches, the maximum static pressure will be limited to 7 bar

Remarks:

The "L" and "H" columns give the minimum dead band values for the Lowest and Highest set point of the range, for a pressure variation of 5% of the measurement range per minute.

The max dead bands correspond to the adjustable dead band electrical codes.

For an explosion-proof housing, the min dead bands should be multiplied by 1.5.

Important remark for proper differential pressure switch operation

To ensure that the contact(s) will change state, the pressure in the HP chamber must be greater than that in the LP chamber. This difference must be greater than the sum of differential pressure (ΔP) + microswitch dead band.

$$HP - LP > \Delta P + e$$

Type	Range ΔP	Adjustable dead band \leq	Max. dead band \geq	Max. static P Min / Max
		1x SPDT 96		
FD .PX	0.5 to 10	0.43	2	0.5 / 13

Example:

For an FD .PX in function 96, the pressure in the HP chamber must be greater than the pressure in the LP chamber by at least:
 $P.HP - P.LP > 0.5 + 0.43 \text{ bar}$
 $P.HP - P.LP > 0.93 \text{ bar}$

Temperature switches: ranges and dead bands

DIRECT BULB TEMPERATURE SWITCHES (VAPOUR PRESSURE)

As standard, the dimensions of FB bulbs are Ø 14 x 120 mm, and 14 x 40 mm for FBA bulbs

Type	Range	1 SPDT												2 SPDT				Max. dead band ≥	T max				
		fixed dead band ≤						adjustable dead band ≤															
	°C	4	10	16	60	6	62	96	34	106	°C												°C
		L	H	L	H	L	H	L	H	L	H	L	H	L	H	L	H	L	H	L	H	L	H
FB.G	-20 to 45	5	1.0	1	0.2	0.6	0.1	2.5	0.6	5	1.0	7	1.6	6	1.5	5.4	1.2	10	2.5	20	7	55	
FB.P	20 to 95	5.5	1.2	1	0.3	0.8	0.2	3	0.7	5.5	1.2	8	1.9	7	2	6.4	1.4	12	3	25	8	105	
FB.R	45 to 120	6	1.4	1.2	0.3	0.8	0.2	3	0.7	6	1.4	10	2.3	7.5	2	6.5	1.6	13	3	25	8	135	
Special ambient temperature switches																							
FBA.GX	-20 to 45	5	1.0	1	0.2	0.6	0.1	2.5	0.6	5	1.0	7	1.6	6	1.5	5	1.0	10	2.5	20	7	55	
● FBA.PX	20 to 70	5.5	1.9	1	0.5	0.8	0.3	3	1	5.5	1.9	8	3.0	7	2.8	5.5	4.5	12	4.5	25	10	70	

● The temperature ranges being given to lower the temperature, the set point selected should not be greater than the max temperature.

BULB AND CAPILLARY TEMPERATURE SWITCHES (VAPOUR PRESSURE)

Differential versions of the temperature switches are also available

Type	Range	1 SPDT												2 SPDT				Max. dead band ≥	T max ▲				
		fixed dead band ≤						adjustable dead band ≤															
	°C	4	10	16	60	6	62	96	34	106	°C												°C
		L	H	L	H	L	H	L	H	L	H	L	H	L	H	L	H	L	H	L	H	L	H
FC.B (X)	-90 to -30	6.5	1.0	1.5	0.3	1.2	0.2	3.5	0.5	6.5	1.0	10	1.3	9	1.3	7.5	1.1	16	2.2	25	5	50	
FC.C (X)	-50 to 10	11	1.8	1.8	0.5	0.7	0.2	3.2	8	11	1.8	15.5	2.7	8	2	13	2.2	10	2.5	20	5	55	
FC.G (X)	-20 to 45	5	1.0	1.2	0.2	0.6	0.1	2.5	0.6	5	1.0	7	1.6	6	1.5	5.4	1.2	10	2.5	20	7	55	
FC.P (X)	20 to 95	5.5	1.2	1.2	0.3	0.8	0.2	3.2	0.7	5.5	1.2	8	1.9	7	2.2	6.4	1.4	12	3.2	25	8	105	
FC.R (X)	45 to 120	6	1.4	1.2	0.3	0.8	0.2	3.2	0.7	6	1.4	10	2.3	7.5	2.2	6.5	1.6	13	3	25	8	135	
FC.R2 (X)	65 to 170	9	2.0	2.2	0.5	1.6	0.3	4.2	0.9	9	2.0	14	2.8	12.5	2.6	10	2.2	17	4	40	12	180	
FC.T (X)	115 to 210	7	1.6	1.2	0.4	0.8	0.3	3.2	1	7	1.6	10	2.5	7	2.5	8	2.0	12	4	25	8	225	
FC.V (X)	150 to 250	7.5	1.8	1.5	0.4	0.8	0.3	3.5	1	7.5	1.8	11	2.5	8.5	2.5	9	2.1	15	4	35	10	265	
FC.V2 (X)	180 to 300	11	2.8	2.5	0.6	1.8	0.4	5	1.2	11	2.8	16	4.0	13.5	3.5	12	3.0	20	5.5	45	15	320	
■ FC.WX	230 to 380	18	2.5	4.2	0.6	3	0.4	10	1.5	18	2.5	25	4.0	25	3.5	21	3.0	34	5.5	50	16	400	

■ At ambient temperatures < +6°C, the instrument is no longer operational: it will resume normal operation without any damage once the temperature has exceeded +6°C (FC.WX only).

▲ On request, these max temperatures can be increased with special ranges. Install probes vertically (capillary output up) or inclined to an angle of 45°. Up to an angle of 75°, please consider the inherent restrictions in respect of the ambient and operating temperatures. For any installations with an angle greater than 75°, please consult us beforehand.

Remarks:

The "L" and "H" columns give the minimum dead band values for the Lowest and Highest set point of the range, for a temperature variation of 0.5°/minute. The max dead bands correspond to the adjustable dead band electrical functions.

For an explosion-proof housing, the min dead bands should be multiplied by 1.5.

These values correspond to the optimum and repeated test conditions for a bulb fully immersed without an immersion pocket in a thermostatic bath of which the type and stirring ensure a precise and homogeneous temperature.

BULB DESIGN AND CAPILLARY LENGTH

T. amb. °C	-20 to 5	5 to 35	35 to 70	-20 to 5	5 to 35	35 to 70	-20 to 5	5 to 35	35 to 70	-20 to 5	5 to 35	35 to 70
Bulb	Ø 9 x 120mm			Ø 10 x 150mm			Ø 14 x 150mm			Ø 14 x 236mm		
Type	◆ ALLOWABLE CAPILLARY LENGTH (METRES)											
FC.B (X)	2			2								
FC.C (X)	-											
FC.G (X)	2			-			2 to 6			2 to 16		
FC.P (X)	2											
FC.R (X)												
FC.T (X)	2 to 6			2 to 20			2 to 20			2 to 20		
FC.V (X)	2 to 6			2 to 20			2 to 20			2 to 20		
FC.WX	2 to 6			2 to 20			2 to 20			2 to 20		

◆ Standard capillary length: 2 metres; other lengths on request

Standard bulb: Ø14 x 150mm stainless steel, Ø10 x 150mm copper (except for ranges around ambient operating temp: Ø14 x 150mm).

Specific features associated with mounting temperature switches

Important remark on probe installation

Thermostatic probes must be installed facing down, with the capillary outlet at the top.

The measurement probe must not be placed in a horizontal position. The position of the probe can affect the operation of the temperature switch. This type of probe is intended for vertical use, and is placed lower than the housing.

Any deviation from these conditions can affect the response time and operation of the device.

By design, our temperature switches are filled to allow probe inclination of 45° without affecting operation. Beyond this value, operation is dependent on the temperature value measured in relation to ambient temperature.

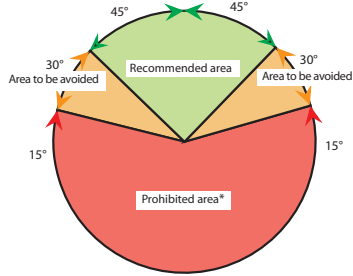

Recommended area: ±45° either side of the vertical axis, bulb down (capillary output up).

Area to be avoided: From 45° to 75°, the operation of the sensor depends on the measured temperature value (Ts) and the ambient temperature (Ta):

Ta > Ts: operation is not affected,

Ta < Ts: operation might be affected,

Ta = Ts: operation is affected.

Prohibited area: Beyond 75°, the operation of the sensor can be significantly affected. This is difficult to predict and depends on several physical parameters. Technical solutions are possible on request (please consult us).

IMMERSION POCKETS (MECHANICALLY WELDED) WITH CAPILLARY CABLE GLAND

For bulb (mm)	A (mm)	B (mm)	C (mm)	D hex w/o flats	E conical	F (mm)	Reference	
							Brass	316L stainless steel
9 x 120	115	16	16	26	G 1/2"	12	GC41	GCX41
10 x 150	145	22	22	29	G 3/4"	◆13	GC1	GCX1
10 x 150	145	22	22	29	G 1/2"	◆13	GC11	GCX11
▲ 14 x 120	105	22	22	29	G 3/4"	17	GB21	GBX21
14 x 150	145	22	22	29	G 3/4"	17	GC21	GCX21
▲ 14 x 120	105	22	22	29	G 1/2"	17	-	GBX61
14 x 150	145	22	22	29	G 1/2"	17	-	GCX61
14 x 236	232	22	22	29	G 3/4"	17	GC25	GCX25

▲ For FB type

◆ Ø14mm for stainless steel

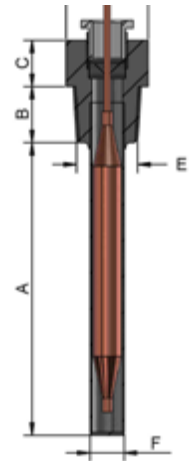

For NPT process connection, add the suffix "B" to the reference, e.g. GCX21B.

For a longer than standard length, add the suffix "-L" to the reference, example = GCX21-L (length "A" to be specified).

For a shorter than standard length, add the suffix "-C" to the reference, example = GCX21-C (length "A" to be specified).

Machined thermometer wells are only supplied when specified by the client.

For bulbs implanted in immersion pockets (except perforated immersion pockets) for gaseous fluid applications, a thermal bridge must be created between the bulb and the immersion pocket using a filler liquid (oil) or a heat-conducting paste.

The technology used by our temperature switches is vapour pressure. This ensures that the measurement will be made only on the bulb, without effect from the temperature in the capillary. As such, for capillary temperature switches, a standard length bulb will be retained even for extra-long bulbs.

CAPILLARY PROTECTION



For all ranges greater than 125°C the sheath length is 10 to 20 cm less than that of the capillary.

CAPILLARY CABLE GLAND

(References such as PC** and PCX**)

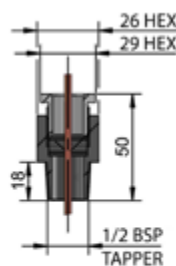

The capillary cable gland helps ensure tightness on the capillary outlet.

This accessory is supplied as standard on the GC and GCX models designated above but is optional on drilled-through designs.

Dimensional drawings

HOUSINGS

Standard housing - Type: F

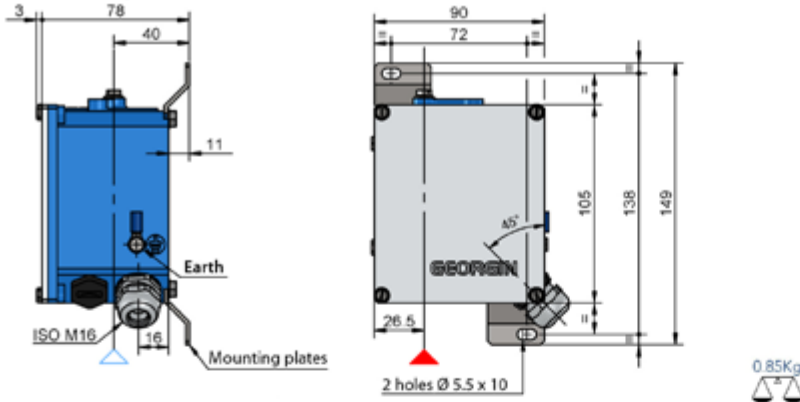

Polyester housing - Type: FPP

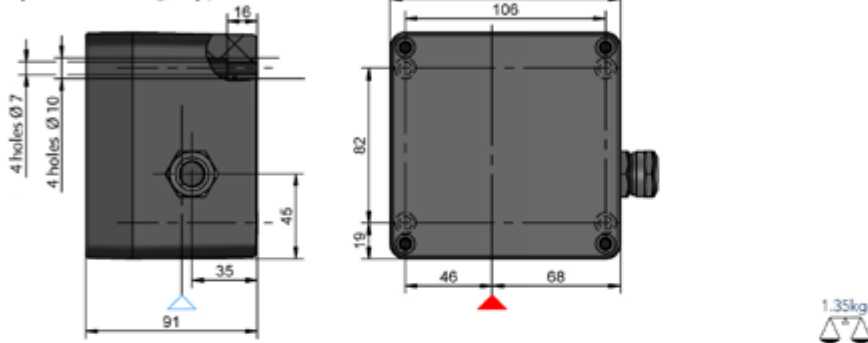

Stainless steel housing - Type: FPX

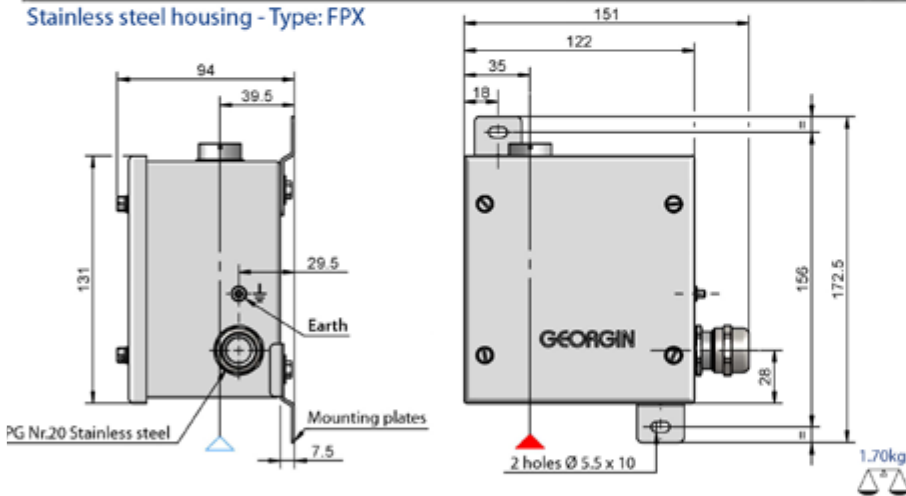

Explosion-proof housing - Type: RTPF

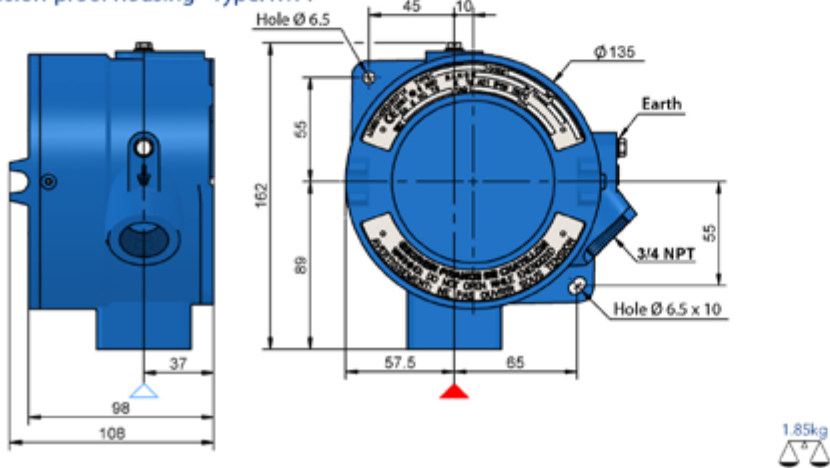

SENSING ELEMENTS (Temperature)

FC

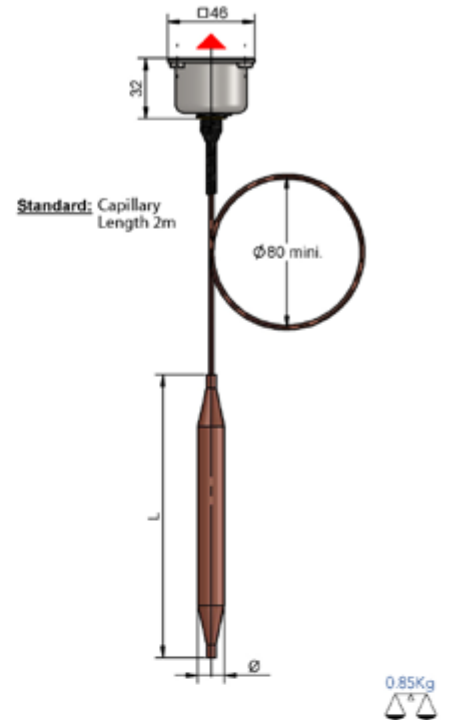

FB

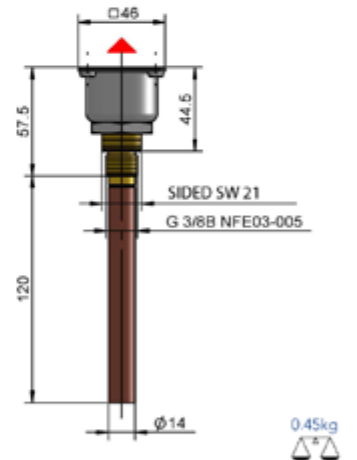

FBA

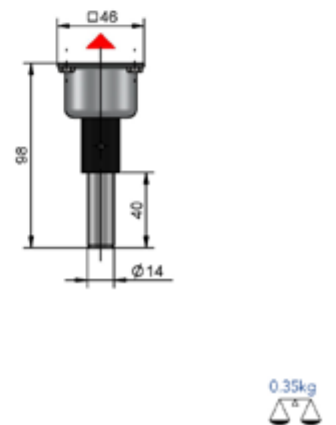

The triangles ▲ (shown on front view) and △ (shown on right-hand view) represent the assembled instrument.

2D or 3D drawings are available as an option to be specified in the order.

Instrument mounting is subject to requirements; please refer to the assembly manual supplied with each instrument beforehand. As such, standard housings are supplied without mounting plates for (D)FML/T/S and with special plates for FD(H) and FV (drawings available on request).

SENSING ELEMENT (Pressure Switches)

DIAPHRAGM

FML/DFML

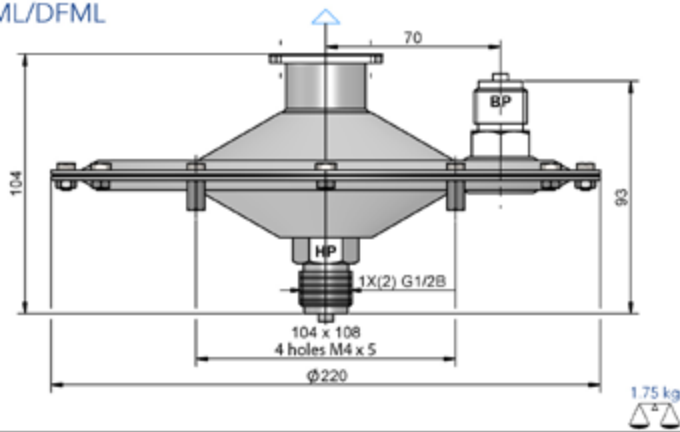

FMT/DFMT

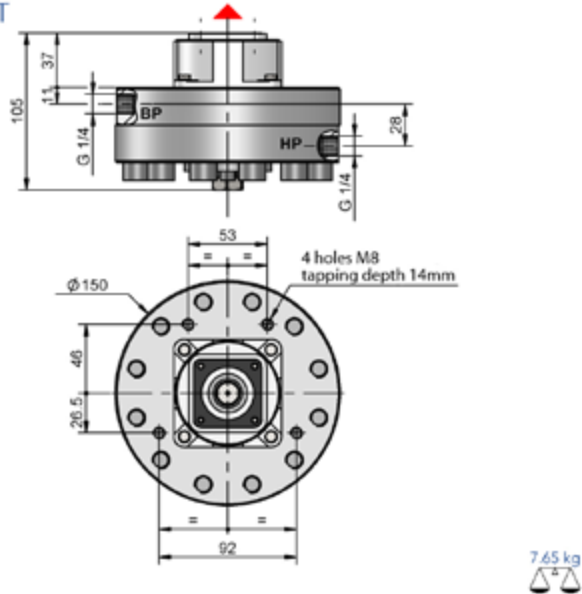

FMS/DFMS

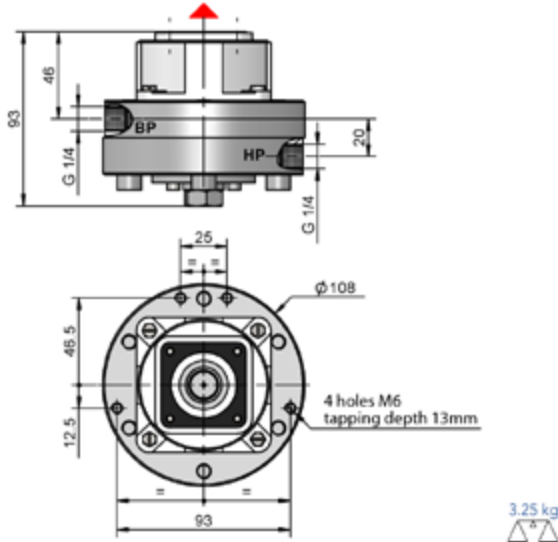

FPA/FPAS

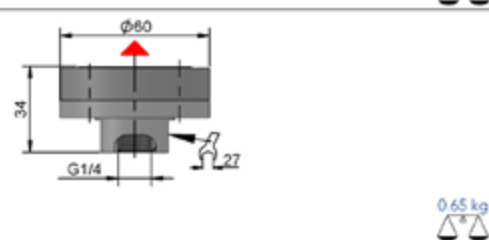

BELLOWS

FP (AX-FX-GX-LX-MX-NX)

FPH (GX)

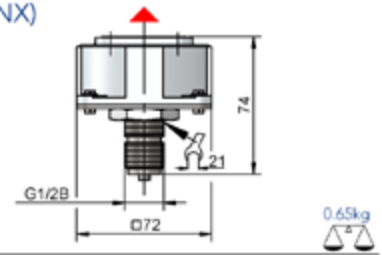

FP (KX-PX-QX-RX-SX)

FPH except (GX)

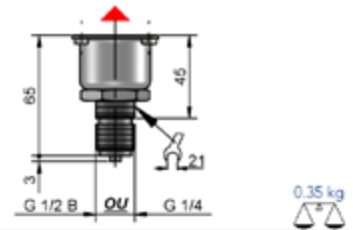

FD (MX-PX-QX-RX-SX) - FDH (NX-PX-QX)

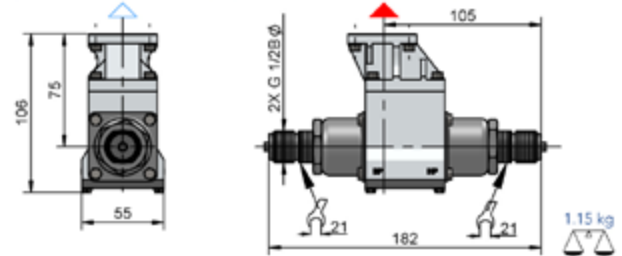

FD (HX-NX) - FDH (GX) - FV

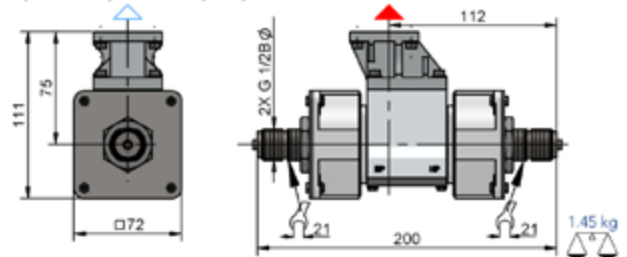

MANOMETRIC TUBE

FPL corrosion proof version

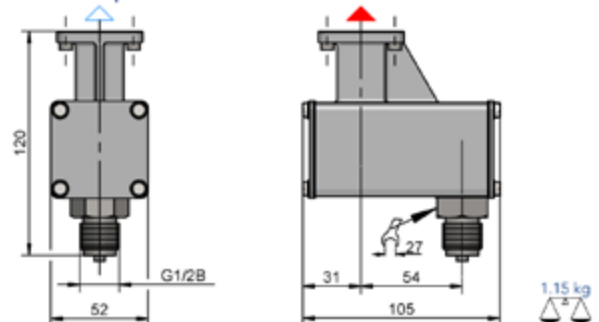

FPL standard version

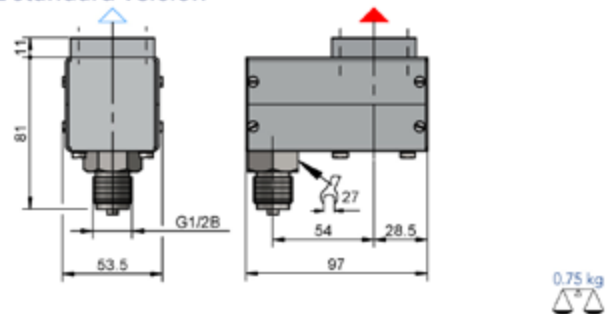

The weights given are approximate and as a rough guide only and may vary according to the designs. The weight of the FC type thermostatic element is indicated for a 2-metre capillary. Dimensions are given in mm.



Safety for Industrial Process

Industrial Range

F series

Pressure switches and temperature switches



■ CERTIFICATION FOR AREAS INVOLVING AN EXPLOSION RISK

F series pressure switches and temperature switches comply with Directive 2014/34/EU and are suitable for installation in areas involving an explosion risk. They are broken down into 4 construction and protection modes:

■ Intrinsic Safety

Installation areas*: 0/1/2 and 20/21/22

■ Increased safety or Explosion-proof safety

Installation areas*: 1/2 and 21/22

■ Constructional safety (for pneumatic equipment)

Installation areas*: 1/2 and 21/22

*The protection index of the instruments affects the installation areas, refer to page 5 for more information.

■ PRESSURE EQUIPMENT DIRECTIVE (PED)

Series F pressure switches satisfy the requirements set forth in Appendix I of PED 2014/68/EU. They are classified in Category IV as a safety accessory, and can be incorporated in a safety loop. Refer to our declaration of compliance for the models concerned and conditions of use.

■ FUNCTIONAL SAFETY - SIL CAPABILITY

Georgin offers a comprehensive range of SIL products and guides its clients in securing their industrial sites to meet Instrumented Safety Function requirements in accordance with the Machinery Directive 2006/42/EC. The reputation of our F series pressure and temperature switches in terms of reliability has been rated based on an operational feedback analysis.

Our products allow SIL2 capability, with no redundancy or external monitoring in accordance with Markov 1oo1 architecture. Refer to the certificates for more information.

■ TECHNICAL REGULATION (TR CU / TR TS) - FORMERLY GOST

TR CU (or TR TS in Russian) is the certificate of conformity for the customs union of the Russian Federation, Belarus, Kazakhstan and Armenia, it states compliance with Russian laws and standards and authorises imports.

Note that, as the metrology certificate is intended for measurement tools, it is not applicable to pressure switches and temperature switches.

■ ELECTRICITE DE FRANCE ACCREDITATION NO. 85

■ NATO ACCREDITATION CODE F3363

■ NACE COMPLIANCE

316L stainless steel Bourdon tube and bellows-actuated pressure switches comply with NACE Standard MR0175/ISO 15156-3-2003.

fc-f-en-20-07-2016



Régulateurs GEORGIN
14-16, rue Pierre Sépard - BP 107 - 92323 CHÂTILLON Cedex France
Tel.: +33 (0)1 46 12 60 00 - Fax: +33 (0)1 47 35 93 98
Email: regulateurs@georgin.com

www.georgin.com